



GUTTER & DOWNPIPE

INSTALLATION GUIDE

Calculating Rainwater Run Off (flow) of Roof

To calculate flow in litres per second for a 75mm/hour rainfall intensity the formula is:

$$\text{Flow (l/s)} = \text{ERA (m}^2\text{)} \times 0.0208 \quad (\text{ERA} = \text{Effective Roof Area})$$

Where:

- H = Ridge to Eaves Height
- H/2 = Half the Ridge to Eaves Height
- W = Roof Span
- L = Length of Roof

Example Flow Calculation

- H = 3m
- H/2 = 1.5m
- W = 3m
- L = 20m

$$\text{ERA} = (\text{H}/2) + \text{W} \times \text{L}$$

$$\text{ERA} = (1.5\text{m}) + 3\text{m} \times 20\text{m}$$

$$\text{ERA} = 4.5\text{m} \times 20\text{m}$$

$$\text{ERA} = 90\text{m}^2$$

$$\text{Flow (l/s)} = 90\text{m}^2 \times 0.0208$$

$$\text{Flow} = 1.87 \text{ l/s}$$

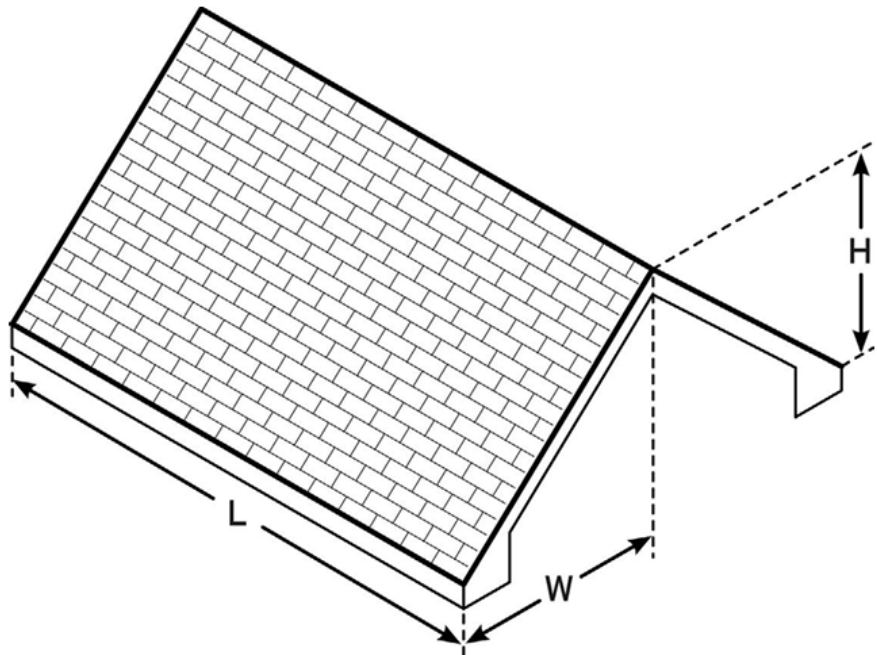

Gutter Capacity

The gutter flow capacity of Freeflow rainwater systems is determined by the profile of the gutter, gutter gradient (fall) and the size and positioning of the outlets.

Best results are obtained where the outlet is at the centre of the longest run of gutter and the gutters are fitted with a 1:600 gradient.

Additionally, if a gutter angle is introduced into the rainwater gutter run the effective gutter flow capacity is reduced.

Choosing Gutter type and Quantity

To determine a suitable gutter profile and quantity based on calculated flow rate, refer to Table 1 and Table 2.

Table 1. Gutter flow capacity with outlet at the centre of the gutter run.

System	Gutter Level	1:600 Gradient
Half Round	1.90 Litres/sec	2.43 Litres/sec
Square	2.20 Litres/sec	3.03 Litres/sec
Ogee	3.90 Litres/sec	4.76 Litres/sec
Deepflow	3.77 Litres/sec	4.60 Litres/sec

Table 2. Gutter flow capacity with outlet at the end of the gutter run.

System	Gutter Level	1:600 Gradient
Half Round	0.95 Litres/sec	1.21 Litres/sec
Square	1.10 Litres/sec	1.55 Litres/sec
Ogee	1.92 Litres/sec	2.36 Litres/sec
Deepflow	1.87 Litres/sec	2.29 Litres/sec

Installation Guide

The Freeflow® rainwater systems we supply may be installed using the steps outlined below. It is important that you refer to the design guidelines outlined at the end of this installation guide prior to beginning your installation project. The design guidelines, exploded view of drawings and products lists in this guide will assist you in selecting the correct type, quantity and sizes of products required.

Fitting Gutter:

- 1 It is important to ensure gutters are fitted as high as possible to the roof edge and the roof edge should not project beyond the centre of the gutter cross section. Gutters can be fitted either level or with a slight fall. Laying the gutter with a fall will increase the flow capacity and increase the area of the roof that can be drained. Silting will also be reduced with a gutter installed with a slight fall.
- 2 Fix the gutter outlet to the fascia with 5mm (minimum) roundhead screws* vertically above the gully from which the rainwater will be conveyed to the drainage system. Use a string-line to ensure a straight gutter, whether level or laid to a fall. Double check the desired fall is achieved, adjust as necessary. Mark out the position of every support point along this line.
- 3 Fix fascia brackets to the fascia along the line created above with 5mm (minimum) roundhead screws* at maximum intervals of 1m. A fascia bracket should be fitted within 150mm of all stopends and angles.
- 4 The fitting of a union bracket is required at each junction of two gutter sections. Fit a stopend to complete the run. Union brackets should be fixed to the fascia with 5mm (minimum) roundhead screws*. Unions should never be allowed to 'float' without fixing.
- 5 Starting at the gutter outlet insert the back edge of the gutter under the retaining lip of the fascia brackets. Then press down on the gutter to snap the front of the gutter in place. Fit additional gutter lengths and gutter lengths cut to size as required. When measuring gutters to be fitted, ensure that the gutter will extend to the marks on the fittings. Fittings are marked to indicate the position to which the gutter should be inserted to allow for thermal expansion.
- 6 All rainwater gutters and pipes must be squarely cut and all burrs removed. It is recommended that a fine toothed saw be used. Care must be taken when cutting gutters and pipes in cold or damp conditions.

NOTE: In areas subject to high winds, extra securing of brackets may be required. Any extra screws deemed advisable should only be secured through holes drilled with the necessary clearance.

Fitting Gutter:

- 1 Fixing of the downpipe starts at the gutter outlet. An offset is generally required to join the gutter outlet or downpipe from the outlet to the downpipe on the wall. Offsets can be constructed from the range of Freeflow bends depending upon the roof overhang. All offsets should be supported directly beneath the lower offset bend by a pipe clip. Remember to allow for thermal expansion as described below.
- 2 Insert a length of square or round downpipe as preferred into the bottom of the offset bend and fix a pipe clip to the wall with 5mm (minimum) roundhead screws*. Ensure that a gap of 10mm is left at the top of the downpipe for thermal expansion. Fix additional pipe clips as required at maximum intervals of 2m. If the downpipe is subject to impact, extra clips should be considered. Two different pipe clip fittings are available, a flush fitting and where a gap is preferable between wall and pipe, a stand off clip.
- 3 Additional lengths of downpipe may be required to reach the ground depending on the height of the building. In this case, fix a socket to the wall with a pipe clip and 5mm (minimum) roundhead screws* at the bottom of the existing fitted downpipe and fix another length of downpipe to the wall as outlined above. Ensure that a gap of 10mm is left at the top of additional downpipes for thermal expansion.
- 4 When all downpipes have been fixed in place, connection to the drainage system can be achieved either by terminating the downpipe with a rainwater shoe for disposal either into a drain or hopper or directly into the underground drainage pipe using a rainwater pipe adaptor. The shoe or adaptor will take the rainwater from the downpipe to the drain thus reducing the possibility of surface water accumulating on the ground.

Notes:

1. All screws should be non-corroding, zinc-plated, stainless steel or similar.
2. In areas prone to heavy snow falls, fascia brackets should be fixed at maximum intervals of 800mm
3. Where, due to the absence of a fascia or the design of the building, support brackets cannot be fixed,

Freefoam offer a range of rafter brackets to suit each profile that is screwed to the rafter. Where a gradient is required, rise and fall brackets can be used. Freefoam supply a range of gutter adapters to connect to existing gutter systems. All adapters must be supported at either side of the connection. It is recommended that the joint be secured by a suitable waterproof sealant.

Testing

When rainwater installations are complete the system should be tested for water tightness under working conditions and internal downpipes should also be tested as prescribed in the relevant Building Regulations. Guidance is also given in BS6367:1983.

Important Note This advice and guidance is based upon typical situations only. For assistance with specific projects, please contact Freefoam Technical Services at info@freefoam.com.

British Standards Freeflow Rainwater systems are manufactured to the following British Standards:

BS4576: - Half round gutters and pipes of circular cross section manufactured in PVC-U.

BS EN 12200 - Plastics rainwater systems for above ground external use manufactured in PVC-U.

BS EN 607 - Eaves gutters and fittings made of PVC-U definitions, requirements and testing.

BS EN 1462 - Brackets for eaves gutters - requirements and testing.

This now completes the installation of the Gutter and Downpipe



 01889 572872

 online@gbplastics.co.uk

 www.gbplastics.co.uk

